

### 9. VVT-i (Variable Valve Timing-intelligent) System

#### General

- The VVT-i system is designed to control the intake and exhaust camshafts within a range of 40° and 35° respectively (of Crankshaft Angle) to provide valve timing that is optimally suited to the engine condition. This improves torque in all the speed ranges as well as increasing fuel economy, and reducing exhaust emissions.

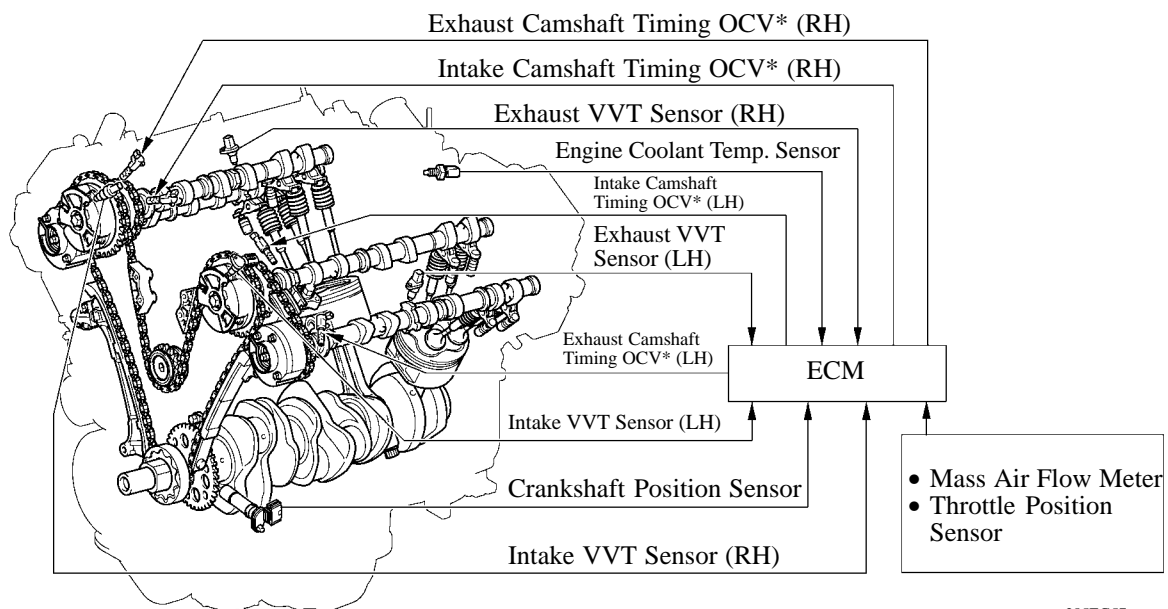

285EG57

\*: Oil Control Valve

- By using the engine speed, intake air volume, throttle position and engine coolant temperature, the ECM calculates optimal valve timing for each driving condition and controls the camshaft timing oil control valve. In addition, the ECM uses signals from the camshaft position sensor and the crankshaft position sensor to detect the actual valve timing, thus providing feedback control to achieve the target valve timing.

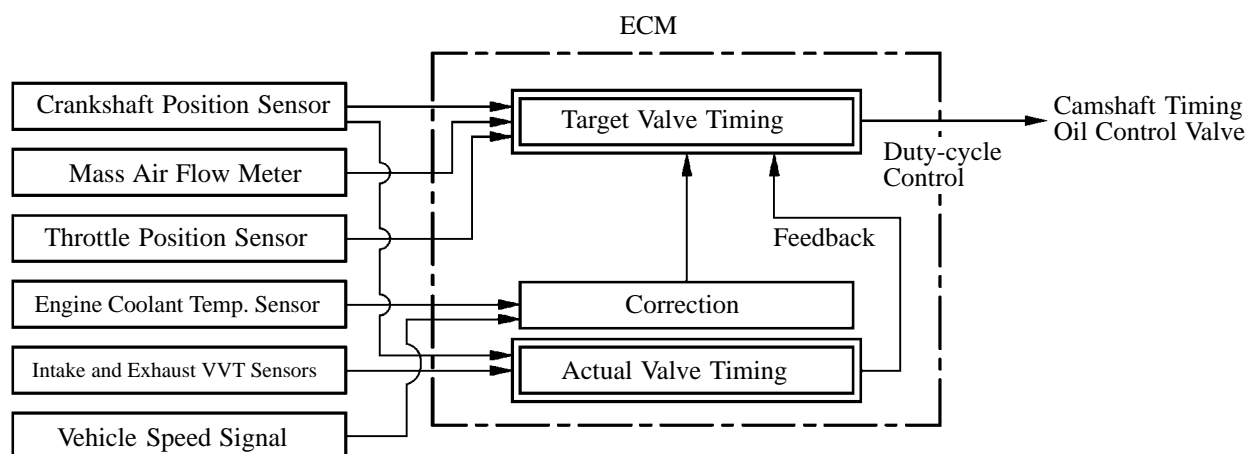

221EG16

**Effectiveness of the VVT-i System**

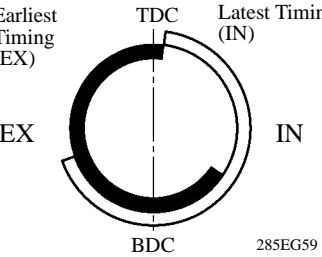
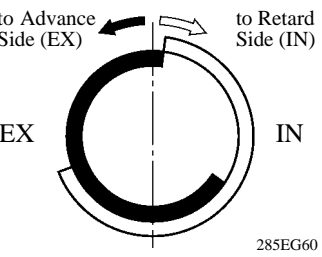
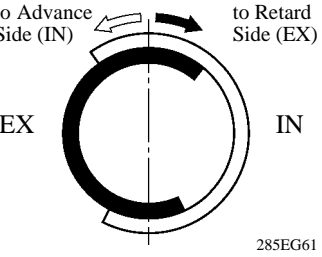
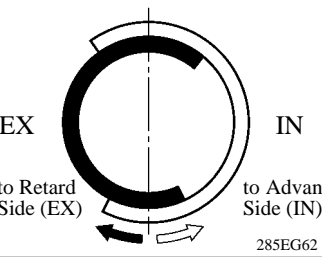
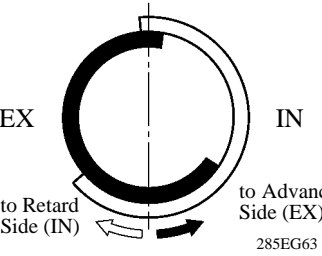
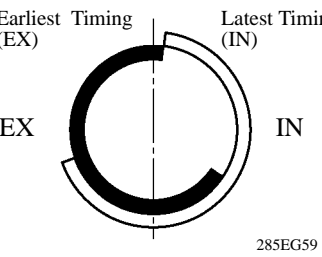
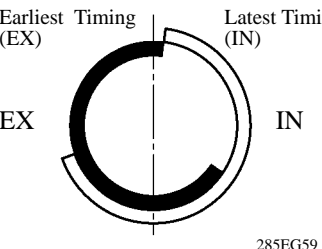
Operation State	Objective	Effect
During Idling	 <p>Eliminating overlap to reduce blow back to the intake side.</p>	<ul style="list-style-type: none"> <li>• Stabilized idling rpm</li> <li>• Better fuel economy</li> </ul>
At Light Load	 <p>Eliminating overlap to reduce blow back to the intake side.</p>	Ensured engine stability
At Medium Load	 <p>Increasing overlap increases internal EGR, reducing pumping loss.</p>	<ul style="list-style-type: none"> <li>• Better fuel economy</li> <li>• Improved emission control</li> </ul>
In Low to Medium Speed Range with Heavy Load	 <p>Advancing the intake valve close timing for volumetric efficiency improvement.</p>	Improved torque in low to medium speed range
In High Speed Range with Heavy Load	 <p>Retarding the intake valve close timing for volumetric efficiency improvement.</p>	Improved output
At Low Temperatures	 <p>Eliminating overlap to reduce blow back to the intake side leads to the lean burning condition, and stabilizes the idling speed at fast idle.</p>	<ul style="list-style-type: none"> <li>• Stabilized fast idle rpm</li> <li>• Better fuel economy</li> </ul>
<ul style="list-style-type: none"> <li>• Upon Starting</li> <li>• Stopping the Engine</li> </ul>	 <p>Eliminating overlap to minimize blow back to the intake side.</p>	Improved startability

## Construction

### 1) VVT-i Controller

- This controller consists of the housing driven from the timing chain and the vane coupled with the intake and exhaust camshafts.
- The intake side has used a VVT-i controller with 3 vanes, and the exhaust side has used one with 4 vanes.
- When the engine stops, the intake side VVT-i controller is locked on the most retarded angle side by the lock pin, and the exhaust side controller is locked on the most advanced angle side. This ensures excellent engine startability.
- The oil pressure sent from the advance or retard side path at the intake and exhaust camshaft causes rotation in the VVT-i controller vane circumferential direction to vary the intake valve timing continuously.
- An advanced angle assist spring is provided on the exhaust side VVT-i controller. This helps to apply torque in the advanced angle direction so that the vane lock pin securely engages with the housing when the engine stops.

#### ► Intake Side VVT-i Controller ◀

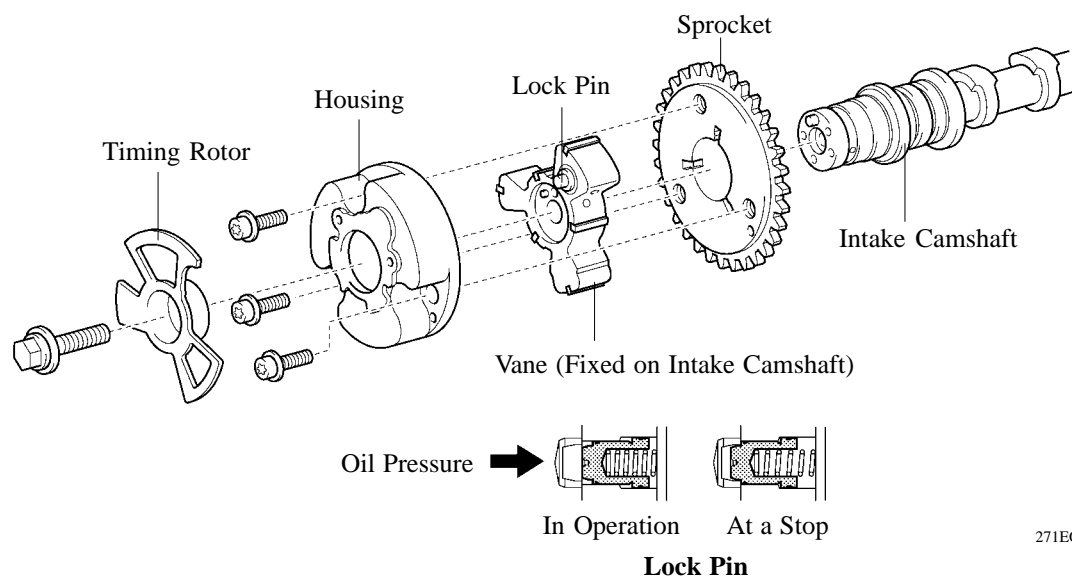

#### ► Exhaust Side VVT-i Controller ◀

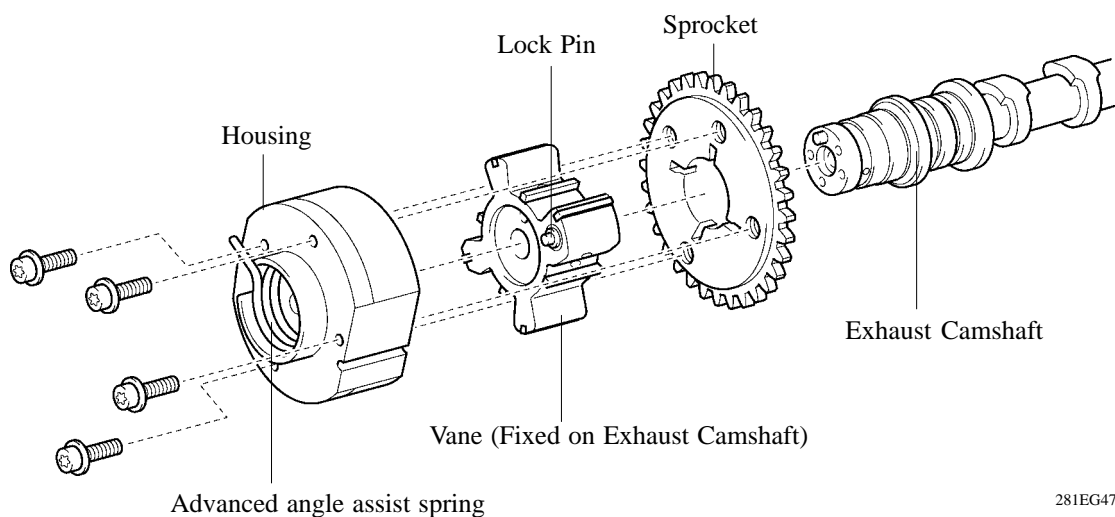

## 2) Camshaft Timing Oil Control Valve

This camshaft timing oil control valve controls the spool valve using duty-cycle control from the ECM. This allows hydraulic pressure to be applied to the VVT-i controller advance or retard side. When the engine is stopped, the camshaft timing oil control valve is in the most retard position.

### ► Intake Camshaft Timing Oil Control Valve ◀

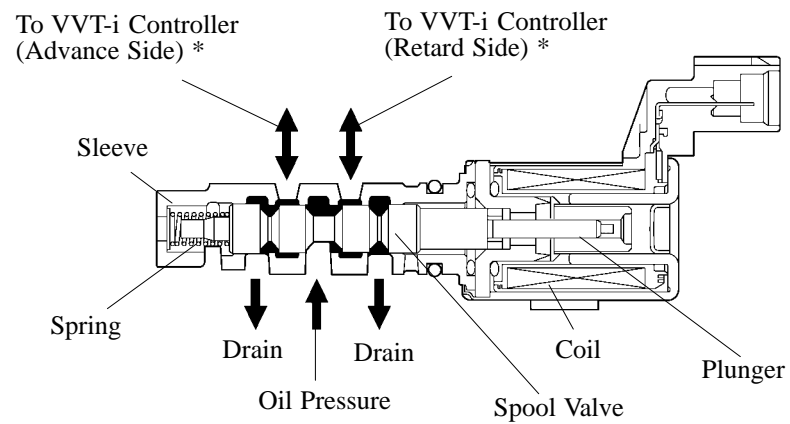

238EG62

\*: The advance and retard sides of the exhaust side oil control valve are reverse of the intake side.

**Operation**

**1) Advance**

When the camshaft timing oil control valve is positioned as illustrated below by the advance signals from the ECM, the resultant oil pressure is applied to the timing advance side vane chamber to rotate the camshaft in the timing advance direction.

**► Intake Side ◀**

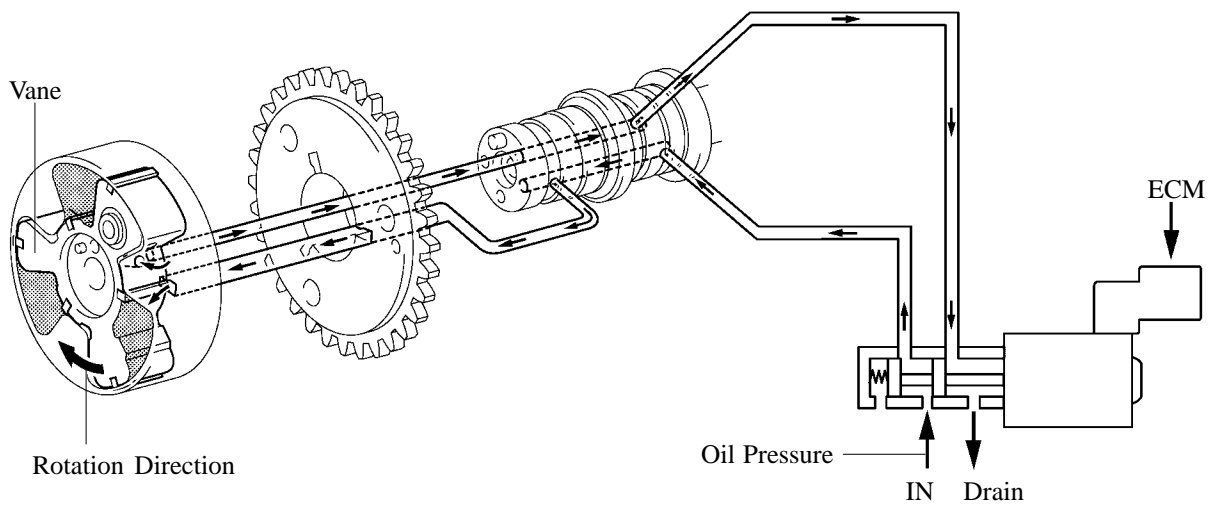

**► Exhaust Side ◀**

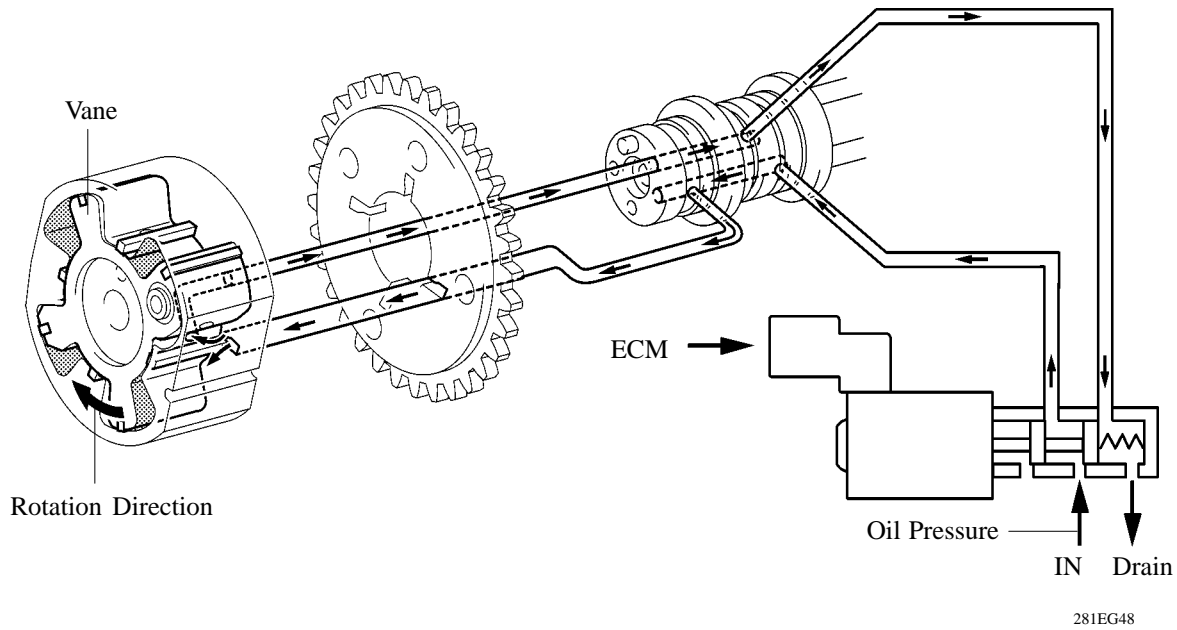

## 2) Retard

When the camshaft timing oil control valve is positioned as illustrated below by the retard signals from the ECM, the resultant oil pressure is applied to the timing retard side vane chamber to rotate the camshaft in the timing retard direction.

### ► Intake Side ◀

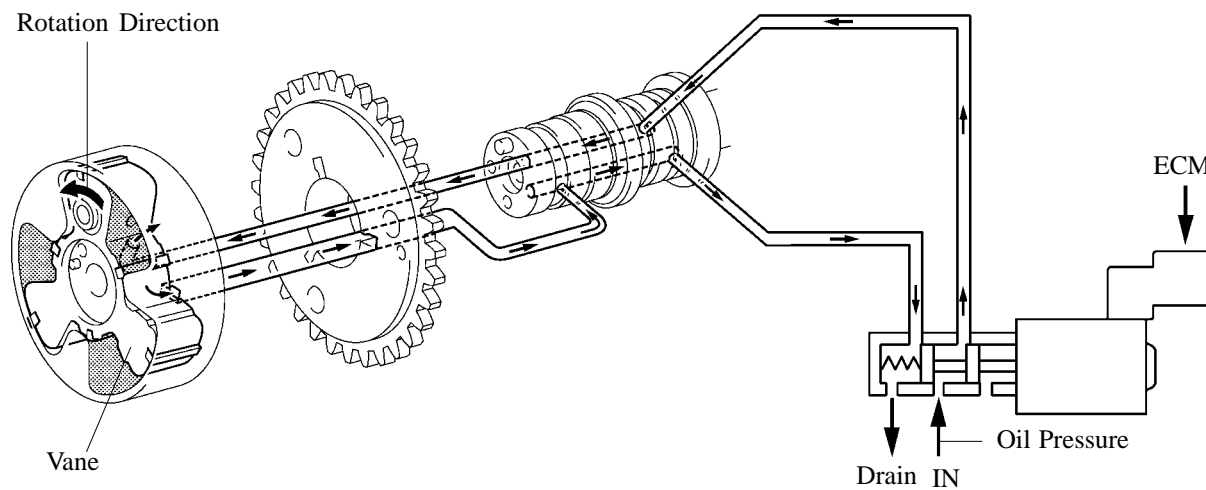

238EG64

### ► Exhaust Side ◀

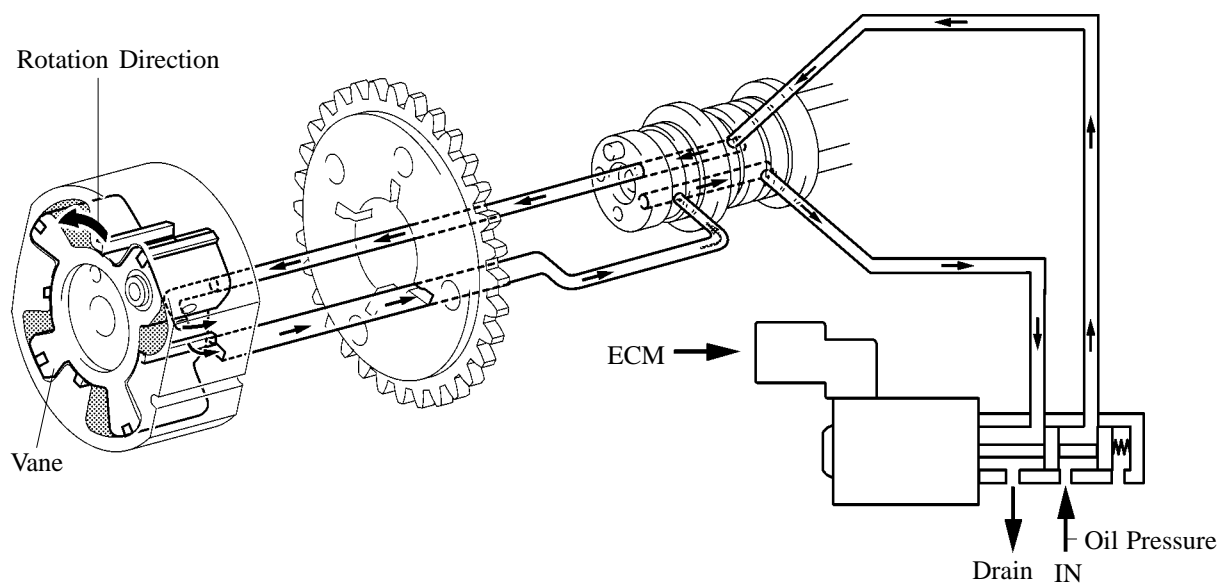

281EG49

## 3) Hold

After reaching the target timing, the valve timing is held by keeping the camshaft timing oil control valve in the neutral position unless the traveling state changes.

This adjusts the valve timing at the desired target position and prevents the engine oil from running out when it is unnecessary.